

Alliance

8L DUAL BASKET AIR FRYER

INSTRUCTION MANUAL & RECIPE GUIDE



Digital
time control



Digital
temperature
control



Easy to
clean
and use

CONTENTS

Important safeguards	3
For household use only	3
Save these instructions	3
Additional important safeguards	4
Notes on the Plug	4
Notes on the Cord.....	5
Plasticizer Warning.....	5
Electric Power.....	5
Getting To Know Your 8.0L Dual Basket air fryer.....	6
Dual Touchscreen Control.....	7-8
Operating Instructions.....	8
8 Menu selections: AIR FRY, ROAST, BROIL, BAKE, REHEAT, KEEP WARM, FRENCH FRIES, DEHYDRATE Pre-Programmed TEMPS & TIMES Chart Manual Operation	8-9
Sync Finish	9
Dual Cook.....	9
Air Fry Technique.....	10-11
Air Frying Pre-Packaged Frozen Foods	11
Hints For Roast.....	11
Hints For Broil	11
Hints For Bake	11
Hints For Dehydrate	12
User Maintenance Instructions.....	14
Care & cleaning instructions.....	14
Storing instructions.....	14
Recipes.....	15-17

IMPORTANT SAFEGUARDS

When using electrical appliances, basic safety precautions should always be followed, including the following:

1. **READ ALL INSTRUCTIONS.**
2. Do not touch hot surfaces. Use handles or knobs. Use oven mitts or potholders.
3. To protect against electric shock do not immerse cord, plugs, or appliance in water or other liquid.
4. This appliance may be used and cleaned by children age 8 and older or by persons with reduced physical, sensory or mental capabilities, or lack of experience and knowledge, **ONLY IF** they have been given supervision or instruction concerning use of the appliance by a person responsible for their safety.
5. Children should be supervised to ensure that they do not play with the appliance.
6. Unplug from outlet when not in use and before cleaning. Allow to cool before putting on or taking off parts, and before cleaning the appliance.
7. Do not operate any appliance with a damaged cord or plug, or after the appliance malfunctions, or has been damaged in any manner. Bring it to a qualified technician for examination, repair or electrical or mechanical adjustment.

NOTE: DO NOT ATTEMPT TO REPAIR THE UNIT YOURSELF. THIS WILL VOID THE WARRANTY.

8. The use of accessory attachments not recommended by the appliance manufacturer may cause injuries.
9. Do not use outdoors.
10. Do not let cord hang over edge of table or counter, or touch hot surfaces.
11. Do not place on or near a hot gas or electric burner, or in a heated oven.
12. Extreme caution must be used when moving an appliance containing hot oil or other hot liquids.
13. To disconnect, press  and pull any active fryer basket(s) out of the Air Fryer body. Remove plug from wall outlet.
14. Do not use appliance for other than intended use. When using the crisping tray(s), make sure they are properly inserted into each air fryer basket before cooking.
15. Make sure the crisping tray is in place before adding food to be air fried.
16. Always make sure any active fryer basket is fully inserted and locked into the front of the Air Fryer before operation.

WARNING: Air Fryer will not operate unless the active fryer baskets are fully closed.

CAUTION: After hot air frying, roasting, broiling, baking, or reheating, the fryer baskets, crisping trays (if used) and the cooked foods are hot. Extreme caution must be used when handling the hot Air Fryer baskets and crisping trays.

FOR HOUSEHOLD USE ONLY

SAVE THESE INSTRUCTIONS

ADDITIONAL IMPORTANT SAFEGUARDS

CAUTION HOT SURFACES: This appliance generates heat and may release steam during use. Proper precautions must be taken to prevent the risk of burns, fires, or other injury to persons or damage to property.

CAUTION: This appliance is hot during operation and retains heat for some time after turning OFF. Always use oven mitts when handling hot materials and allow metal parts to cool before cleaning. Do not place anything on top of the appliance while it is operating or while it is hot.

1. All users of this appliance must read and understand this instruction manual before operating or cleaning this appliance.
2. The cord to this appliance should be plugged into a 220-240V electrical outlet only.
3. If this appliance begins to malfunction during use, press  and pull any active fryer basket(s) out of the body. Remove plug from wall outlet. Do not use or attempt to repair the malfunctioning appliance. Contact Consumer Service.
4. Do not immerse power cord in any liquid. If the power cord to this appliance is damaged, it must be replaced.
5. Keep the cord out of reach from children and infants to avoid the risk of electric shock and choking.
6. Place the Dual Basket Air Fryer on a flat, stable, heat-resistant work area.
7. Do not obstruct the air outlet or air inlets on the back and sides of the Air Fryer, with any objects. Avoid escaping steam from the air outlet during air frying.
8. Keep appliance at least 4 inches away from walls or other objects during operation.
9. Always use each fryer basket handle to remove each fryer basket. **WARNING:** Under- or over-filling the fryer basket may damage the Air Fryer and could result in serious personal injury.
10. Never move a hot Air Fryer or an Air Fryer containing hot food. Allow to cool before moving.

WARNING! This Air Fryer should not be used to boil water.

WARNING! This Air Fryer should never be used to deep fry foods.

Notes on the Plug

This appliance has a polarized plug (one blade is wider than the other). To reduce the risk of electric shock, this plug will fit in a polarized outlet only one way. If the plug does not fit fully into the outlet, reverse the plug. If it still does not fit, contact a qualified electrician. Do not modify the plug in any way.

ADDITIONAL IMPORTANT SAFEGUARDS

Notes on the Cord

- A. A short power-supply cord (or detachable power-supply cord) is to be provided to reduce the risk resulting from becoming entangled in or tripping over a longer cord.
- B. Longer detachable power-supply cords or extension cords are available and may be used if care is exercised in their use.
- C. If a long detachable power-supply cord or extension cord is used :
 1. The marked electrical rating of the cord or extension cord should be at least as great as the electrical rating of the appliance;
 2. If the appliance is of the grounded type, the extension cord should be a grounding-type 3-wire cord;
 3. The longer cord should be arranged so that it does not drape over the countertop or table top where it can be pulled on by children or tripped over unintentionally

Plasticizer Warning

CAUTION: To prevent Plasticizers from migrating from the finish of the counter top or table top or other furniture, place NON-PLASTIC coasters or place mats between the appliance and the finish of the counter top or table top. Failure to do so may cause the finish to darken; permanent blemishes may occur or stains can appear.

Electric Power

If the electrical circuit is overloaded with other appliances, your appliance may not operate properly. It should be operated on a separate electrical circuit from other appliances.

Getting To Know Your 8.0L. Dual Basket Air Fryer

Product may vary slightly from illustration

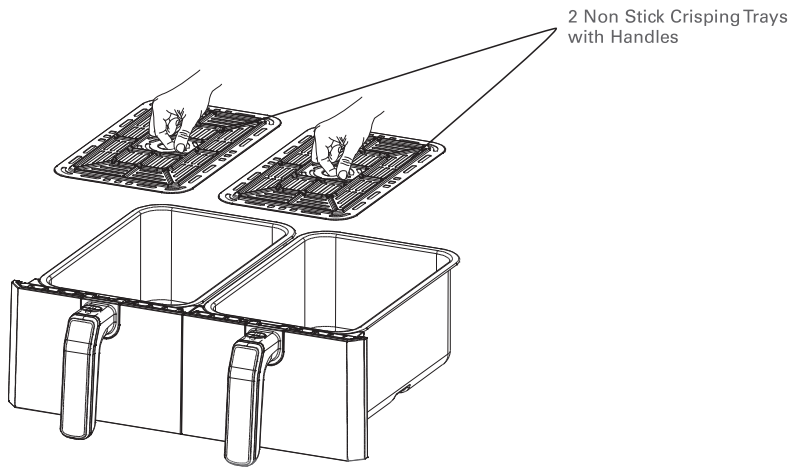
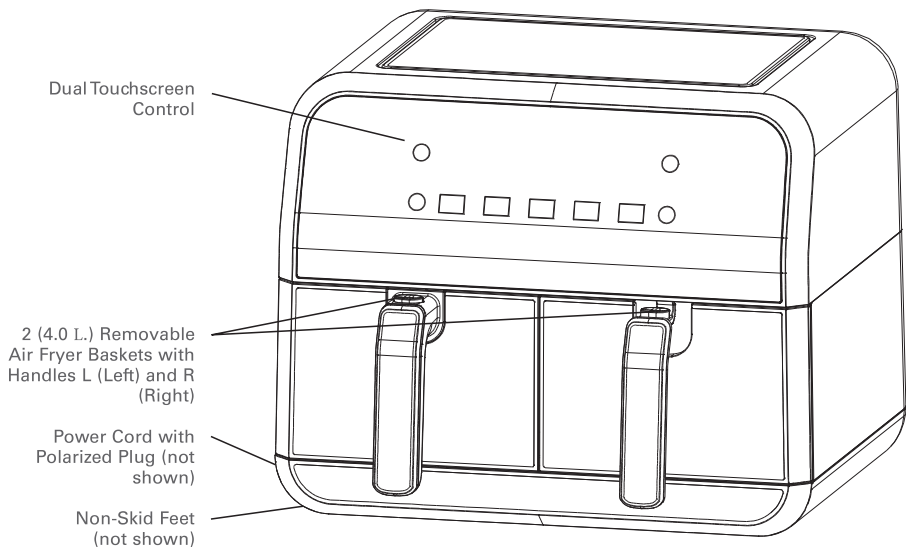

Dual Touchscreen Control

1. ON/OFF
2. Dual Digital TIME/TEMP Display
3. LEFT / RIGHT Basket Control
4. AIR FRY
5. ROAST
6. BROIL
7. BAKE
8. REHEAT
9. KEEP WARM
10. FRENCH FRIES
9. DEHYDRATE
10. TEMP and
11. TIME and
12. SHAKE FOOD
13. SYNC FINISH
14. DUAL COOK
15. START/PAUSE



ON/OFF

- When the Air Fryer is plugged in, a tone will sound, the control panel will illuminate, then disappear. The button will light up red, indicating that the unit is powered on.
- When is pressed, a tone will sound, the will turn green, and the , , and buttons will light up.
- When in operation, press to turn both LEFT and RIGHT basket controls OFF.

LEFT/RIGHT Basket Control

- When the pulsing is pressed, a tone will sound, you can select to use the left or right basket independently, or dual cook to use both at the same time.
- Press the or button to program the Left or Right basket. While Left or Right flashes, press any MENU button to continue.
NOTE: LEFT or RIGHT baskets may be programmed independently, at any time before or during operation.
- The or button will illuminate steadily on the screen when active. To adjust or add programming at any time, press the appropriate or basket control button. When the button begins to flash, TEMP/TIME can be adjusted.

TEMP (or) / TIME (or)

- Press or on the left side of the control panel to increase or reduce TEMP in 5 degree increments.
- Press or on the right side of the control panel to increase or decrease TIME in 1 minute increments.
NOTE: When using DEHYDRATE, TIME will increase or decrease in 1 hour increments.
NOTE: LEFT or RIGHT basket TIME and/or TEMP may be programmed independently, at any time before or during operation. Press the LEFT or RIGHT button. When LEFT or RIGHT begins to flash, programming can be adjusted.

SHAKE

- For all menu selections except BROIL, REHEAT AND DEHYDRATE, 5 tones will sound at 2/3 of the cook time, to remind you to shake the basket.
- Press to turn this feature OFF. SHAKE will disappear from the screen.
NOTE: shake will not work if cooking time is below 3 minutes

DUAL COOK

- Press to effortlessly duplicate settings for both LEFT and RIGHT Air Fryer baskets or select Dual cook to program Left and Right basket at the same time. After pressing , you can simply adjust the temperature and time for both baskets at the same time

SYNC FINISH

- Both LEFT and RIGHT baskets must first be programmed.
- Press to ensure both baskets will complete cooking together.
- HOLD will appear on the display as the Dual Air Fryer synchronizes the final cook times.
NOTE: Once cooking has started SYNC function will not be operable.

START/PAUSE

- Once programming is complete, press to START the cooking process or to PAUSE any operation.

Before Using for the First Time

Remove all packing material and labels from the inside and outside of the Air Fryer. Check that there is no packaging underneath and around each of the fryer baskets and crisping trays.

1. Your Dual Basket Air Fryer is shipped with the 2 crisping trays locked into each fryer basket inside the Air Fryer body.
2. Firmly grasp each fryer basket handle, to pull fryer baskets out of the main body.
3. Grasp each crisping tray handle and lift to remove from each basket. (Figure 1)
4. Wash both fryer baskets and crisping trays in hot, soapy water.
5. **DO NOT IMMERSER THE AIR FRYER BODY IN WATER.** Wipe Air Fryer body with a damp cloth. Dry all parts thoroughly.
6. Replace crisping trays into each fryer basket. With the handle facing up, insert each tray so that the rubber corners fit and lock comfortably into each basket.
7. Due to base unit's gracious front curve, the air fryer baskets must be inserted into the proper sides. The tops of the drawers are labeled L (LEFT) and R (RIGHT). Slide the LEFT air fryer basket/crisping tray into the left side of the Air Fryer body. Slide the RIGHT air fryer basket/crisping tray into the right side of the body. Before use, make sure each basket is fully inserted and locked into place. (Figure 1)

NOTE: During first use, the Dual Air Fryer may emit a slight odor. This is normal and will not affect flavor.

Figure 1

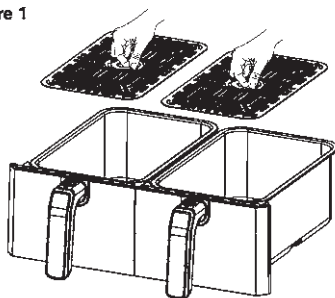

Operating Instructions

IMPORTANT! The maximum food capacity recommended for each Air Fryer basket is 4.0 litres of food per basket. Using both baskets will enable you to feed up to 9 people. **WARNING!**

This Dual Basket Air Fryer should not be used to boil water.

WARNING! This Dual Basket Air Fryer should never be used to deep fry foods.

1. Place the Dual Basket Air Fryer on a flat, stable, heat-resistant work area, close to an electrical outlet.
2. If needed, add crisping tray(s). See "Before Using for the First Time" for a detailed description.
3. Place food into either or both fryer baskets. Do not overfill. To ensure proper cooking and air circulation, NEVER fill any fryer basket more than 2/3 full. When air frying fresh vegetables, we do not recommend adding more than 2 to 3 cups of food to the fryer basket.

NOTE: Up to 6 cups of ingredients may be dehydrated as food will shrink to a fraction of its original volume. Place a single layer of ingredients into the empty air fryer basket. Create a second layer by placing the crisping tray into the basket over the ingredients. Add food on top of the crisping tray. .

4. Insert the assembled fryer basket(s) into the front of the Dual Basket Air Fryer. Always make sure fryer basket(s) are in their proper LEFT/RIGHT position and they are fully closed.

8 Menu Selections: AIR FRY, ROAST, BROIL, BAKE, REHEAT, KEEP WARM, FRENCH FRIES, DEHYDRATE Pre-Programmed TEMPS & TIMES

Chart Manual Operation

Menu	Default TEMP	Default TIME	TEMP Range	TIME Range	SHAKE Food
AIR FRY	200 °C	20 mins	80 °C - 230 °C	1 - 60 mins	2/3 time/ 1x
ROAST	200 °	35 mins	180°C - 230 °C	1 - 60 mins	2/3 time/ 1x
BROIL	230 °C	10 mins	230 °C	1 - 30 mins	not recommended
BAKE	180 °C	16 mins	80 °C - 200 °C	1 - 60 mins	2/3 time/ 1x
REHEAT	121 °C	6 mins	80 °C - 200 °C	1 - 60 mins	not recommended
KEEP WARM	80 °C	60 mins	70 °C - 90 °C	1 - 60 mins	not recommended
FRENCH FRIES	180 °C	18 mins	80 °C - 200 °C	1 - 60 mins	2/3 time/ 1x
DEHYDRATE	55 °C	8 hours	30°C - 80°C	1 hr- 24 hrs	not recommended

1. Plug cord in the wall outlet. An audible tone will sound, the control panel will illuminate. The **⏻** button will light up red.
2. When the **⏻** is pressed, a tone will sound and the power button will turn green, the control panel will illuminate LEFT, RIGHT and **DUAL COOK** (Figure 2)
3. Select **[L]**, **[R]**, or **DUAL COOK**. Press the desired MENU button. A tone will sound. The LEFT or RIGHT basket control and both the default TEMP (in large numerals) and default TIME (smaller numerals) will flash on the display and alternate between time and temperature. (Figure 3)

Figure 2



Figure 3



Single Basket: Manual Operation

1. For single basket cooking, press **START PAUSE** to START the cooking process. (Figure 4)
2. For dual basket cooking, press the other basket control. (Figure 5) MENU selections will appear.

Figure 4

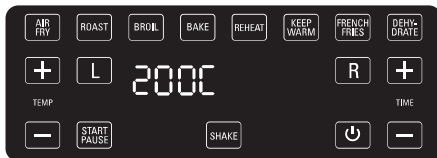

Figure 5



3. Press the desired MENU button for RIGHT basket cooking.
4. Press **START PAUSE** to START the cooking process.
5. When the selected LEFT basket control begins to flash, press any MENU button to continue. (Figure 3)
6. When both the TEMP and TIME light up, press TEMP **[+]** or **[-]** to increase or reduce TEMP in 5 degree increments.
 - NOTE:** Press and hold the TEMP button to fast advance.
7. Press TIME **[+]** or **[-]** to increase or decrease TIME in 1 minute increments.
 - NOTE:** Press and hold the TIME button to fast advance.
 - NOTE:** In the dehydrate setting, time is adjusted in 1 hour increments
8. When the desired TIME and TEMP appear on the digital display, press **START PAUSE** to turn the Dual Basket Air Fryer ON. The target TIME will begin to count down. TEMP and remaining TIME will appear on the digital display. (Figure 4)
 - NOTE:** To pause air frying immediately, push the basket release button and pull the active fryer basket out of the body at any time. When the basket is replaced, cooking will resume.
 - NOTE:** Press **START PAUSE** to PAUSE the cooking process. at any time. When **START PAUSE** is pressed again, cooking will resume.
9. When the remaining TIME reaches 00:00, the display will show "Cool Cool" and change to "End End" and beep 5 times when it is safe to remove food.
 - NOTE:** The quantity, density, weight of food will alter the total cooking time necessary. Remember, frying smaller batches will result in shorter cooking times and higher food quality.
 - IMPORTANT:** Always check food halfway through cooking time to determine final cook TIME and TEMP.
10. To adjust the air frying TEMP or TIME during operation, use the TEMP or TIME **[+]** or **[-]** to increase or decrease TEMP or TIME as you cook.

Dual Basket: Manual Operation

1. Program the Air Fryer LEFT basket following Single Basket: Manual Operation Steps 5 through 10.
2. Press the RIGHT basket control. (Figure 6). The menu will appear.
3. Press the desired MENU button for RIGHT basket cooking. Adjust TEMP or TIME as needed. A tone will sound to confirm your selection.
4. Press **START PAUSE** to begin operation. (Figure 7)

SYNC FINISH

1. Program the Dual Air Fryer LEFT and RIGHT baskets following Dual Basket: Manual Operation Steps 1 through 3.

IMPORTANT: Both LEFT and RIGHT baskets must first be programmed.

2. Press **SYNC FINISH** to ensure both baskets will complete cooking together. Press **START PAUSE** to begin operation.
3. HOLD will appear on the display on the basket side that is being held as the Dual Air Fryer synchronizes the final cook times. (Figure 8)

NOTE: Once cooking has started SYNC function will not be operable.

DUAL COOK

1. Press **DUAL COOK**. Settings for the both Air Fryer basket will be automatically duplicated. (Figure 9)
2. Press **START PAUSE** to begin operation.

Figure 6



Figure 7

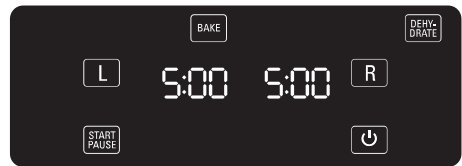

Figure 8



Figure 9



Air Fry Technique

Please consult the Air Fry / Roast Cooking Chart and/or follow package directions for suggested TIME and TEMP.

1. Always pat food dry before cooking to encourage browning and avoid excess smoke.
2. To assure even cooking/browning, ALWAYS open the active basket halfway through the cook time and check, turn or shake foods in the fryer basket. Some recipes may call to brush or spray oil halfway through cooking. Adjust TEMP or TIME if needed.

WARNING: Extreme caution must be used when handling any hot fryer basket or crisping tray. Avoid escaping steam from the fryer basket and the food.

CAUTION: Always use oven mitts when handling the hot air fryer basket.

CAUTION: Hot oil can collect at the base of the basket. Use caution when removing cooking foods.

3. To avoid excess smoke, when cooking naturally high fat foods, such as bacon, chicken wings or sausages, it may be necessary to empty fat from the fryer basket between batches.
4. To ensure crispiness, make sure the skin or exterior surface of your food is dry! Air fry small batches of freshly breaded foods. Create more surface area by cutting food into smaller pieces. Press breading onto food to help it adhere. Refrigerate breaded foods for at least 30 minutes before frying.
5. To improve crispiness, dust poultry skin or exterior surface lightly with corn starch. Spray with oil.
6. Arrange breaded food in fryer basket so that food is not touching to allow air flow on all surfaces.
7. Spray oils work best. Oil is distributed evenly and less oil is needed. Canola, olive, avocado, coconut, grapeseed, peanut, or vegetable oil work well.
8. Shake air fried foods out onto serving area. Promptly insert any fryer basket into Air Fryer body and lock into place. Continue air frying subsequent batches, if any. 9. Press REHEAT to air fry food for 6 minutes at 250°C. Simply pull out the active basket to interrupt air frying at any time to check on food serving temperature. Repeat to extend cook time until food is heated to your liking.
10. Unplug the Dual Basket Air Fryer when not in use.

Air Frying Pre-Packaged Frozen Foods

- As a rule, depending on the food and amount to be cooked, suggested cook posted cook TIMES may have to be reduced slightly. Always check food halfway through cooking time to determine final cook TIME and TEMP.
- Always check cooking progress after TIME has expired.

Hints For Roast

- A meat thermometer inserted into the center of the meat should always be used to ensure desired doneness.
- Cook meats to 5 to 10 degrees below desired doneness (internal temperature). Allow meat to stand 15 to 20 minutes before serving. The temperature will continue to rise while standing.
- ROAST large, tender cuts of meat and poultry. Seasoning prior to cooking adds to the flavor and the aroma during cooking.
- A layer of fat on the top of the roast promotes better browning and provides natural basting.
- To speed up browning, brush lean cuts of meat, chicken and fish with oil, margarine or melted butter.
- Place meat (fat side up) and turn over half-way through ROAST time.
- **IMPORTANT:** Turn and check food halfway through ROAST time.
- Press  to turn this feature OFF. SHAKE will disappear from the screen.

Hints For Broil

- Use BROIL to melt cheese or to brown crumb toppings.
- Typically, BROIL is used for thinner, tender cuts of meats, or marinated meats, chops, poultry or fish, fruits and vegetables
- Dry marinated meats and fish before broiling. ALWAYS pat meat dry to reduce smoke and promote brownness during broiling.
- To speed up browning and add lusciousness, brush lean cuts of meat, chicken and fish with oil or melted butter.
- Trim excess fat from meat and score edges to prevent curling.
- Thaw frozen meats and fish before broiling.
- BROIL TIME is determined by the desired doneness Always use a meat thermometer.

Hints For Bake

- When using BAKE, you may need to lower the bake recipe temperature by 10°C to a minimum of 150°C.
- Check package directions to determine if the container is suitable for use in an Air Fryer.
- Press  to turn this feature OFF. SHAKE will disappear from the screen.

Hints For Dehydrate

NOTE: When manually programming DEHYDRATE menu selection, TIME will increase or decrease in 1 hour increments.

- Dehydrate fresh, ripe foods to preserve nutrients and enhance flavor.
- Your Dual Basket Air Fryer's automated drying makes home dehydration both simple and rewarding and ensures healthy, safe, preservative-free results.
- DEHYDRATE combines low, steady heat with steady convection fan power.
- Precise low temperatures dry out foods evenly without cooking or overheating.

NOTE: Turn food several times during DEHYDRATE .

Air Fry / Roast Cooking Chart

Times are estimated and based on average sizes and weights.

ALWAYS USE A MEAT THERMOMETER TO ENSURE THAT MEAT, POULTRY AND FISH ARE COOKED THOROUGHLY BEFORE SERVING.

NOTE: Frying smaller batches will result in shorter cooking times and higher food quality. Adjust air frying TEMP and TIME as necessary to suit your taste. **NOTE:** Unless food is pre-packaged and pre-oiled, for browned and crispy results, all foods should be lightly oiled before air frying.

		Single Basket	Dual Basket
Vegetables	Temp	Time	Time
Asparagus, 1 bunch thin spears	200 °C -	5-7 min	10-14 min
Asparagus, 1 bunch thick spears	200 °C	7-9 min	12-15 min
Cauliflower Florets, 3-4 cups	200 °C	13-18 min	18-25 min
Egg Plant, cubes (roasted)	200°C	15 min	24 min
Kale, 3 cups, stems removed	190°C	9 min	15-18 min
Peppers, Bell chunks	190 °C	10 min	15-20 min
Pickles, breaded	200 °C	5-7 min	9-13 min
Potatoes, white, French Fries, (fresh soaked)	200 °C	16-20 min	30-40 min
Potatoes, white, cubed	200 °C	12-14 min	24-35 min
Potatoes, white, wedges	200 °C	20-25 min	35-40 min
Broccoli Florets, 3-4 cups	200 °C	15-20 min	22-28 min
Brussels Sprouts, 450g	190°C	12-15 min	20-25 min
Corn on the Cob, 4 ears	200°C	12-15 min	18-20 min
Carrots, 2 1/2 cups, pieces	200°C	10-12 min	20-24 min
Mushrooms, 3 cups sliced	200 °C	10-12 min	18-22 min
Peppers, Jalapeno, poblano (roasted)	190 °C	10 min	12-15 min
Zucchini discs	200°C	14-17 min	22-24 min
Root Vegetables, chunks (roasted) oasted)	200 °C	15-20 min	25-40 min

		Single Basket	Dual Basket
Beef	Temp	Time	Time
Hamburger, (up to 4 patties)	180 °C	12-16 min	16-18 min
Hot Dogs / Sauages	180 °C	10-15 min	20-25 min
Meat Loaf, 450g	180 °C	33-40 min	45-50 min
Steak, 2 x (220g) Steaks	180 °C	8-21 min	10-24 min
Beef Tenderloin,	180 °C	16 min	18-20 min
Beef Tenderloin, 450g, medium	180 °C	18 min	20-24 min

		Single Basket	Dual Basket
Chicken	Temp	Time	Time
Chicken Breast, boneless, skinless	180 °C	18-20 min	22-25 min
Chicken Thighs, 170g - 220g ea, boneless	180 °C	20-25 min	28-30 min
Chicken Tenders/Fingers: battered	180 °C	13-15 min	16-19 min
Chicken Wings, 900g	200 °C	22-27 min	40-45 min

		Single Basket	Dual Basket
Pork	Temp	Time	Time
Lamb Loin Chops	200 °C	8-12 min	14-18 min
Pork Chops	190 °C	10 -14 min	20-25 min
Pork Chops	190 °C	15-19 min	22-28 min

		Single Basket	Dual Basket
Fish and Sea Food	Temp	Time	Time
Shrimp, thawed and battered	190 °C	12 min	14-15 min
Catfish Fingers, thawed and battered	190 °C	10-15 min	18-25 min
Shrimp, thawed and sauced	160 °C	5-8min	10-12 min
Salmon Filets, thawed	200°C	9-12 min	17-24 min

		Single Basket	Dual Basket
Frozen Foods*	Temp	Time	Time
Cheese Sticks	180 °C	6-9 min	10-12 min
French Fries, Thick, 2 cups	200 °C	17-21 min	24-30 min
French Fries	200 °C	15-17 min	20-24 min
Onion Rings	180 °C	12-16 min	18-22 min
Chicken nuggets, 340g	180 °C	10-15 min	17-22 min
Fish Sticks	200 °C	12-18 min	18-22 min
Meatballs	200 °C	7-9min	11-14 min
Pizza	180°C	12-15 min	15-17 min

*All items are to be air fried from frozen (do not thaw).

		Single Basket	Dual Basket
Deserts	Temp	Time	Time
Apple Turnovers	200 °C	10 min	14 min
Donuts	180 °C	8 min	9-11 min

Dehydrate Chart

- Turn food several times during DEHYDRATE for even drying.

Herb	Temp	Time	Herb	Temp	Time
Oregano	60 °C	2-3 hrs	Parsley	60 °C	2-3 hrs
Thyme	60 °C	3-4 hrs	Rosemary	60 °C	2-3 hrs
Tarragon	60 °C	3-4 hrs	Sage	60 °C	3-4 hrs
Kale Chips Stems Removed	60 °C	2-3 hrs			

Fruit / Vegetables

Wash all fruit skins well.

Slice fruit into 6mm thick slices and arrange with space between each slice to ensure even drying.

Rotate foods halfway through DEHYDRATE time for even drying.

Dehydrate	Temp	Time	Dehydrate	Temp	Time
Apple Rounds Core	60 °C	8-9 hrs	Orange Slices Fully dried Citrus is crisp when fully dried	60 °C	10 hrs
Mango/Papaya Pieces	60 °C	8-10 hrs	Tomatos Roma Skin side down	60 °C	8-9 hrs
Kiwi	60°C	6 hrs	Tomatoes, Cherry/Grape Skin side down	65 °C	5-9 hrs

User Maintenance Instructions

This appliance requires little maintenance. It contains no user-serviceable parts. Any servicing requiring disassembly other than cleaning must be performed by a qualified appliance repair technician.

Care & Cleaning Instructions

WARNING! Allow the Dual Basket Air Fryer to cool fully before cleaning.

1. Unplug the Dual Basket Air Fryer. Remove fryer baskets from the Air Fryer body.
Make sure both fryer baskets and crisping trays have cooled completely before cleaning.
2. Wash both fryer baskets and crisping trays in hot soapy water. Do not use metal kitchen utensils or abrasive cleansers or cleaning products as this may damage the non-stick coating.
3. Both fryer baskets and crisping trays are dishwasher-safe. For best results, place in the top rack of your dishwasher to clean.
4. Wipe the Dual Basket Air Fryer body with a soft, non-abrasive damp cloth to clean.

Storing Instructions

1. Make sure the Dual Basket Air Fryer is unplugged and all parts are clean and dry before storing.
2. Never store the Dual Basket Air Fryer while it is hot or wet.
3. Insert each clean crisping tray into each fryer basket and store inside the Dual Basket Air Fryer body.
4. Store Dual Basket Air Fryer in its box or in a clean, dry place.

RECIPES

Sync Finish Dinner

Honey Ginger Chicken Wings & Air Fried Asian Rutabaga Fries

Serves: 2 or 3

Honey Ginger Chicken Wings

These delicious chicken wings are bathed in a rich, thick simple caramel sauce of made of honey, tamari and freshly grated ginger. A perfect balance of sweet salty ginger spiciness, these wings can be dangerously addictive.

- 450g (6 large) whole chicken wings, split into flats, drums, and tips
- 1/2 cup tamari
- 1/4 cup rice vinegar
- 1/2 cup toasted sesame seeds
- 4 green onions, chopped
- 1 tablespoon toasted sesame oil
- 1 piece of fresh ginger, peeled and minced
- 1/4 cup honey

1. In a large bowl, prepare sauce. Combine all ingredients except chicken wings. Mix well. Add chicken wings and stir until chicken is thoroughly immersed.
2. Cover and chill for 1 hour. Remove chicken. Reserve sauce.
3. Add sauce to a medium saucepan, and bring to a boil. Reduce heat to simmer and cook until reduced by half. Set honey ginger sauce aside and keep warm.
4. Add 6 split wings to the LEFT Air Fryer basket.
5. Program the LEFT Dual Air Fryer basket to AIR FRY at 185°C for 20 minutes.

Air Fried Asian Rutabaga Fries

Rutabaga is a little known root vegetable -- a cross between a cabbage and a turnip. The rutabaga has grown in popularity as a low-carb option that rivals the potato when it comes to snacking and overall deliciousness.

- 1 small rutabaga
- 1 tablespoon olive oil
- 1 tablespoon toasted sesame oil
- 1 tablespoon tamari
- 1/2 teaspoon Chinese five-spice powder

1. Use a potato peeler or a paring knife to peel the rutabaga. Then slice the rutabaga into 1/4-inch discs. Slice each disk into sticks.
2. Toss the rutabaga fries and Asian sauce into a large zippered bag and shake until all raw rutabaga fries are coated.
3. Place 2 to 3 cups of raw rutabaga sticks into the RIGHT Dual Air Fryer basket.
4. Program the RIGHT Dual Air Fryer basket to AIR FRY at 220°C for 15 minutes.
5. Press SYNC FINISH to ensure both baskets will complete cooking together. Press  to begin operation. HOLD will appear on the display as the Dual Air Fryer HOLDS the Rutabaga Fries to synchronize the final cook times.
NOTE: Shake the rutabaga basket every 5 minutes.
6. Before serving, test chicken for doneness. Increase cook time if necessary.
7. In a large bowl, add the reserved honey ginger sauce and the wings; toss to coat.
8. Transfer to a platter and sprinkle Honey Ginger Chicken Wings with toasted sesame seeds and green onions. Serve with Asian Rutabaga Fries.

RECIPES

Drizzled Fried Eggplant Stax

Serves: 2 or 3

We've simplified this recipe for easy weeknight or party preparation. Serve Eggplant Stax as a luscious appetizer. Basil pesto is slathered over air fried eggplant discs topped with shredded mozz and a freshly roasted tomato slice. Finish the presentation with a drizzle of aged balsamic vinegar.

- olive oil cooking spray
- 1 medium eggplant
- 1 cup Italian seasoned Panko breadcrumbs
- 2 tablespoons mayonnaise
- 2 tablespoons plus 1/2 cup Italian basil
- pesto, separated
- 1 cup freshly shredded mozzarella
- 2 to 3 plum tomatoes
- Balsamic vinegar, for drizzling

1. Slice eggplant into rounds.
2. In a small bowl, combine mayonnaise and pesto. Brush onto each disc.
3. Firmly press breadcrumbs into each eggplant disc. Place coated eggplant on a plate and allow rest for 5 minutes.
4. Program the Dual Air Fryer to AIR FRY at 185°C for 8 minutes.
5. Place 6 breaded eggplant rounds into the air fryer basket. Spray tops with olive oil.
6. At the SHAKE alarm, turn each disc over, spray with olive oil, and continue air frying. If discs are not tender, extend cook time 2 minutes or until done to your liking.
7. Roast tomatoes. Cut tomatoes into slices. Add to the RIGHT air fryer basket. Program the Dual Air Fryer to ROAST at 200°C for 8 minutes.
8. Top each eggplant round with pesto, then cheese and 1 slice roasted tomato. If desired, stack another round, add pesto and cheese. Top with tomato and more cheese.
9. Return basket back into the Dual Air Fryer and BROIL for 2 minutes, or until cheese melts to your liking.
10. Drizzle Eggplant Stax with balsamic vinegar before serving.

Boneless Breaded Roasted Pork Chops & Honey Baked Apples

Serves: 8

Down Home Delicious! Pork chops paired with hot and steamy Honey Baked Apples. A hearty, simple, satisfying meal as delicious as it is easy to make. We prepared the pork in 2 batches while the apples were baking.

- olive oil cooking spray
- 900g boneless center cut pork chops, cut into 8 (110g) chops
- 8 teaspoons Dijon mustard
- 8 teaspoons mayonnaise
- 1 cup Italian seasoned breadcrumbs

Marinade:

- 1 cup apple cider or juice
- 4 teaspoons brown sugar
- 4 teaspoons Worcestershire sauce

1. Whisk marinade ingredients together in a large covered container or zipper bag. Marinate pork for up to 4 hours.
2. Remove chops from marinade.
3. In a small bowl, combine mayonnaise and mustard.
4. Smear 2 teaspoons mustard mayo all over each pork chop. Roll chops into the breadcrumbs and press into place. Repeat with the remaining chops.
5. Add 4 breaded pork chops to either basket. Program the Dual Air Fryer to ROAST at 190°C for 10-14 minutes.
6. At the SHAKE alarm, turn chops over.
7. Remove first batch of pork chops and add repeat procedures for the second batch.

RECIPES

Honey Baked Apples

- 4 golden delicious apples, cored (may substitute any apple of your choice)
 - 2 tablespoons butter, divided
 - 4 tablespoons honey
 - Cinnamon to taste
1. Wash and core apples.
 2. Fill each with 1 tablespoon butter and 1 tablespoon honey.
 3. Add prepared apples to the empty basket. Program the Dual Air Fryer to BAKE at 180°C for 30 minutes.
 4. Press SHAKE FOOD to turn this feature OFF.
 5. Check Honey Baked Apples for softness. Increase cook time if necessary.
 6. Cut each apple in half. Sprinkle with cinnamon before serving.

Customer Support
www.allianceair.co.za

